

Installation

Tip: Install product on bench before connecting second hose to mixer.

1. Cut a single 35mm diameter hole into the mounting surface.
2. Insert o-ring into the groove in the bottom of the base ring, fit the base ring to the bottom of the mixer and connect hose.
3. Feed the mixer's hose through the hole cut in the mounting surface.
4. Position the mixer where required and connect twin stud fixing kit. Tighten in place from under the mounting surface.
5. Insert the remaining flexible hose through the hole in the mounting surface (from the underside) and screw it into the base of the mixer.
6. Connect the flexible hoses to the hot and cold supplies (hot on the right, cold on the left).

Note: Ensure that the inline filter washers supplied are fitted during this connection.

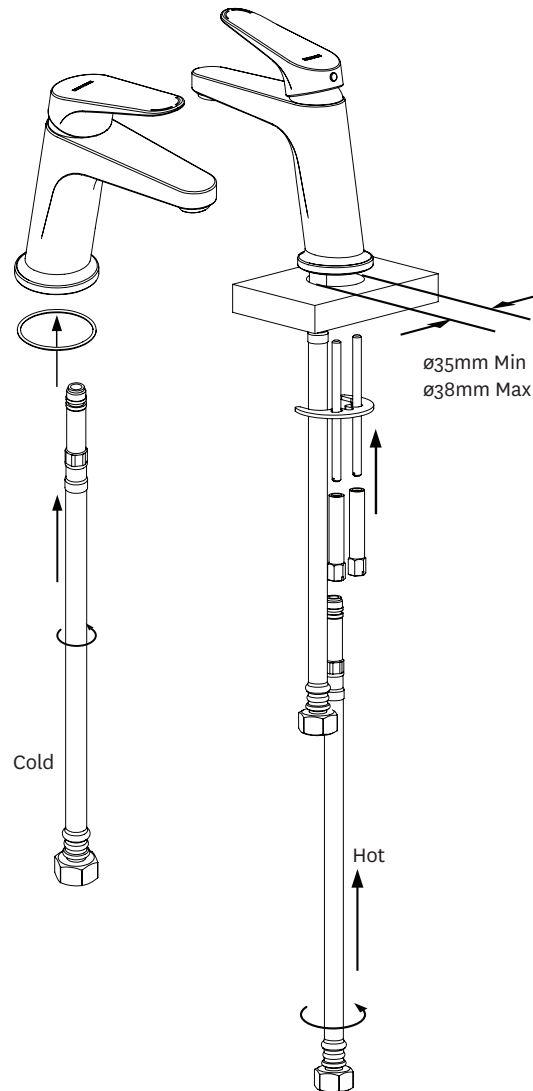

MA018505

Maku Basin Mixer

01-8505

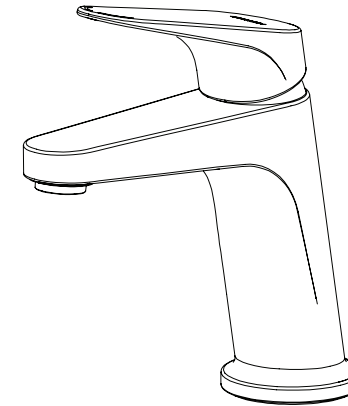

Installation Guide

IMPORTANT

Please read all of the instructions before installation

Use of this product is recommended for domestic and commercial applications. All pipework must be thoroughly flushed prior to the installation of the mixer. Inline filter washers must be installed on both hot and cold supplies to prevent foreign particles damaging the ceramic cartridge. Do not remove the ceramic cartridge from the mixer when installing.

Methven recommends a licensed plumber carry out all installations in compliance with the requirements of AS/NZS 3500. This product complies with AS/NZS 3718 regulations.



JUNE 2012

Methven Australia Pty Ltd

ABN 15 104 813 390
Melbourne, Australia
www.methven.com

www.methven.com

Customer Care Hotline: 1300 METHVEN (638 483)
Email: info@au.methven.com

Technical Specification

Inlet Connections:	All 1/2" BSP
Operating Pressure:	150kPa - 500kPa
	For optimum performance hot and cold water pressures should be equal.
	AS/NZS 3500 stipulates a 500kPa maximum operating pressure at any outlet within a building. Where normal pressure exceeds 500kPa, a pressure limiting valve must be installed.
	This basin mixer is rated at 7.5l/m. If limited water flow is experienced, locate stream shaper flow restricting device and filter washers and clean away foreign material as required.
Operating Temperature:	Recommended hot water supply 50°C, maximum 70°C. AS/NZS 3500 requires all hot water supplies to any sanitary fitting to be tempered to 50°C.
Ceramic cartridges:	The ceramic cartridge can be damaged due to the presence of the following within the water supply:
	Copper tube pieces
	Plastic pieces
	Sand, dirt or stones
	Thread tape
	Other objects not normally present in the potable water supplies

Hose Requirement for Mixers

Do not hydrostatic test* the installation with this mixer installed. Damage to the ceramic cartridge may occur.
 *Hydrostatic testing refers to placing the system under pressure, above the recommended operating pressure, to determine water tightness and to uncover leaks or weak joints within the system.

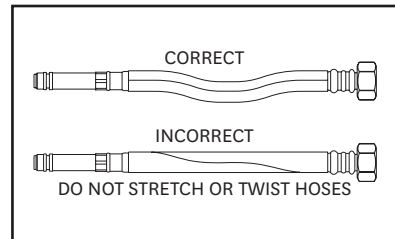
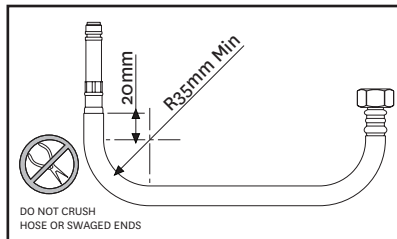

Care and Cleaning

Never use abrasives to clean this product. Clean regularly with contamination free warm soapy water and a damp soft cloth.

