

Installation

1. Leave plastic template on body assembly (1)
2. Screw the body assembly (1) on to the mounting stud positioned to observe installation depth, ID (to front of finished wall lining e.g. tiles) as follows:
Range of Install Depth, **ID** = 36-66 mm
3. Connect body assembly (1) into system and replace body assembly cover.
4. Wall lining e.g. tiles should be finished as close as possible to the plastic template. Remove plastic template prior to next step.
5. Lubricate the o-ring in the faceplate (2). Place faceplate (2) over mixer body and slide firmly over the mixer body until flat on the wall surface. It is recommended that a bead of silicone sealant is applied to the back of the faceplate before fixing to the finished wall surface.
6. Screw half dome (2) on to body assembly (1). Fit handle (4) and fasten grub screw (5) with 2.5mm hex key (6).

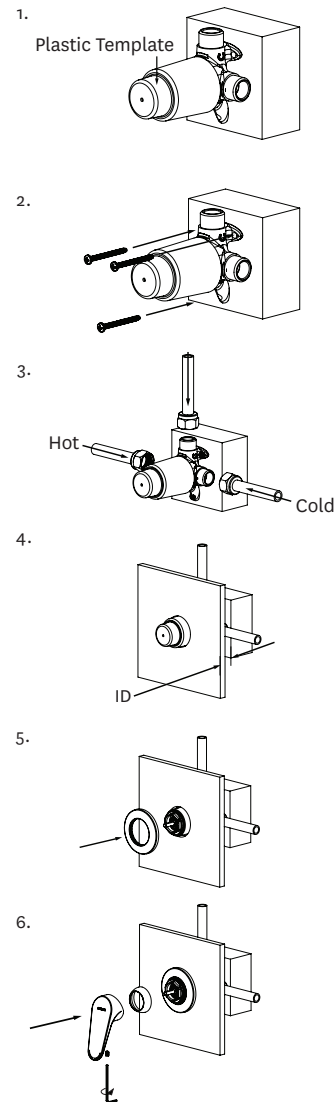

Maku Shower Mixer

01-8567

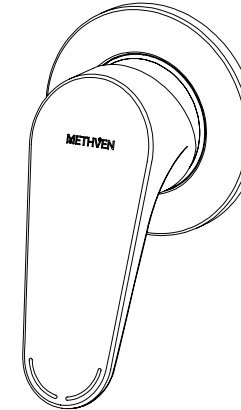

Installation Guide

IMPORTANT

Please read all of the instructions before installation

Use of this product is recommended for domestic and commercial applications. All pipework must be thoroughly flushed prior to the installation of the mixer. Inline filter washers must be installed on both hot and cold supplies to prevent foreign particles damaging the ceramic cartridge. Do not remove the ceramic cartridge from the mixer when installing. Damage caused by hydrostatic testing is not covered by Methven's warranty.

Methven recommends a licensed plumber carry out all installations in compliance with the requirements of AS/NZS 3500. This product complies with AS/NZS 3718 regulations.



JUNE 2012

MA018567

Methven Australia Pty Ltd

ABN 15 104 813 390
Melbourne, Australia
www.methven.com

www.methven.com

Customer Care Hotline: 1300 METHVEN (638 483)
Email: info@au.methven.com

Technical Specification

Inlet Connections:	All 1/2" BSP
Operating Pressure:	150kPa - 500kPa
	For optimum performance hot and cold water pressures should be equal.
	AS/NZS 3500 stipulates a 500kPa maximum operating pressure at any outlet within a building. Where normal pressure exceeds 500kPa, a pressure limiting valve must be installed.
Operating Temperature:	Recommended hot water supply 50°C, maximum 70°C. AS/NZS 3500 requires all hot water supplies to any sanitary fitting to be tempered to 50°C.
Ceramic cartridges:	The ceramic cartridge can be damaged due to the presence of the following within the water supply:
	Copper tube pieces
	Plastic pieces
	Sand, dirt or stones
	Thread tape
	Other objects not normally present in the potable water supplies

Piping Requirements for Mixers

Avoid restrictive piping, fitting or sharp angled bends when plumbing the mixer.

Do not hydrostatic test* the installation with this mixer installed. Damage to the ceramic cartridge may occur.

*Hydrostatic testing refers to placing the system under pressure, above the recommended operating pressure, to determine water tightness and to uncover leaks or weak joints within the system.

Care and Cleaning

Never use abrasives to clean this product. Clean regularly with contamination free warm soapy water and a damp soft cloth.

