

Warranty info

Proof of purchase will be required.

The guarantee does not cover faults or damage caused by incorrect installation and/or maintenance, ordinary wear and tear, water composition, etc.

* Please see www.methven.com for full terms and conditions of warranty

Cleaning

Your product has a high-quality finish and should be treated with care to preserve the visible surfaces. Never use abrasives or abrasive cleaning agents to clean this product clean regularly with contamination free warm water and a damp soft cloth. Do not use products containing chlorine bleach or hydrochloric acid as these can damage the product.

We have a policy of continuous improvement and reserve the right to change specifications without notice.

METHVEN UK LIMITED
METHVEN EXPERIENCE CENTRE
3/3A STONE CROSS COURT
YEW TREE WAY
GOLBORNE
WARRINGTON
WA3 3JD
UNITED KINGDOM
INST-KRCTSEFCP-V1

TEL: 0800 195 1602
FAX: 0844 406 8690
EMAIL: sales@uk.methven.com
www.methven.com

KIRI MK2 CHROME COOL TOUCH BAR C/W EASY FIT SHOWER KIT KRCTSEFCP Installation Guide

Technical Specification

Operating Pressure

Min: 1.0 Bar

Max: 5.0 Bar

Operating Temperature

Hot: 65°C

Cold: 5°C

Inlet Connections

15mm Compression



METHVEN
www.methven.com EST 1886

Please read all of the instructions before installation.

General

Methven recommends this product is installed by a competent person in compliance with all relevant regional regulations.

After installation all connections must be checked for leaks.

All outlets used primarily for personal hygiene shall deliver water at a safe temperature as per regional regulations. It is the responsibility of the installer to ensure a waterproof seal is achieved.

Testing Method

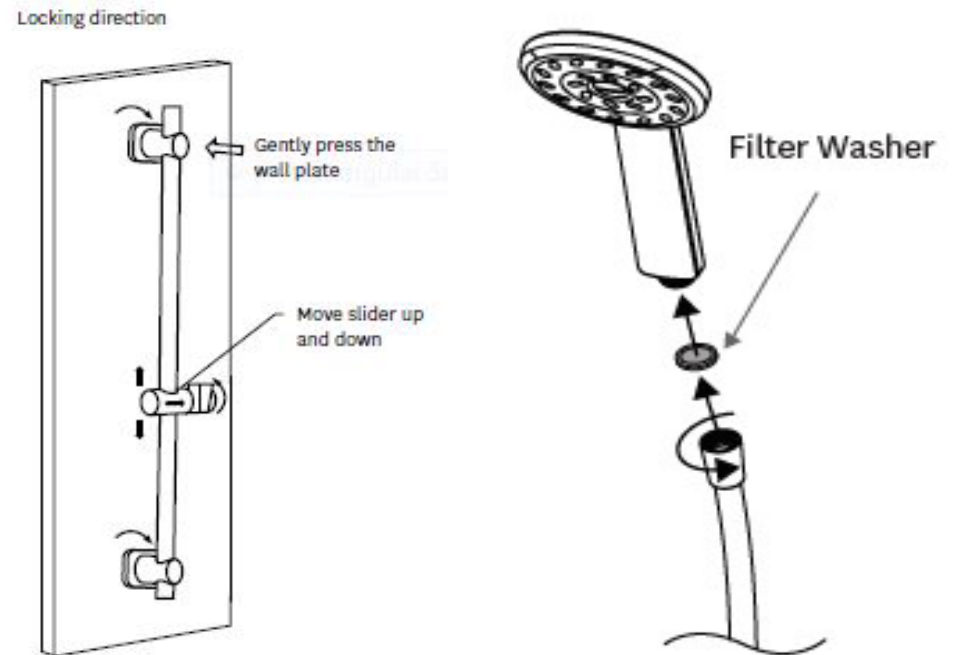

- 1) Use a 6mm drill bit to drill a hole in the wall at the desired height, drill a second hole vertically lower at a recommended height of 550mm. In certain
- 2) Assemble the handset slider, soap dish and hose retainer on to the rail ensuring button is facing upward. Attach both rail end assemblies.
- 3) Ensuring the handset slider button is facing upwards as shown in the illustration, adjust the two rail end assemblies to match the position of the wall bracket.
- 4) Gently press the rail end assemblies onto the wall brackets, until the rail ends touch the wall. Turn both wall covers clockwise into the locking position,
- 5) Insert flat washer into the shower hose before screwing to the handset. Connect the other end of the shower to the shower outlet.

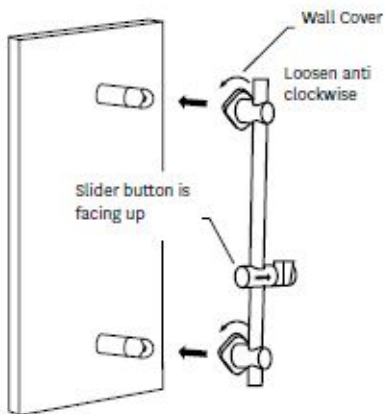
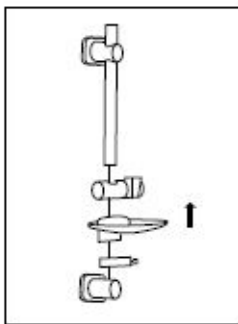
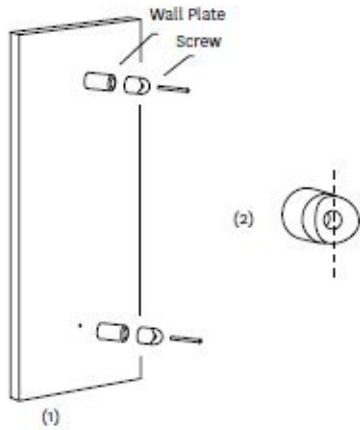

Installation Instructions

- 1) Prepare the Hot and Cold supply pipes at 150mm centres.
- 2) Ensure the holes for the pipes are not made too big as this will affect drilling of the screw holes for the mounting brackets.
- 3) Ensure that there is approximately 22mm of pipework left exposed proud of the finished tiled wall to establish the correct installation connection.
- 4) Apply an appropriate amount of sealant between the pipe and wall lining to create a watertight seal.
- 5) Place the mounting plate over the pipework.
- 6) Take one of the threaded connectors, slide the connector over the pipework and loosely fit the threaded connector into the mounting bracket. This will ensure that the pipework is central to the mounting bracket.
- 7) Using the mounting bracket as a template, mark the positions of the holes to be drilled.
- 8) Remove the threaded connector, slide the mounting bracket off the pipework.
- 9) Drill and plug the wall in position as previously marked. Note: Ensure you use the correct type of wall plugs to suit your particular installation conditions.

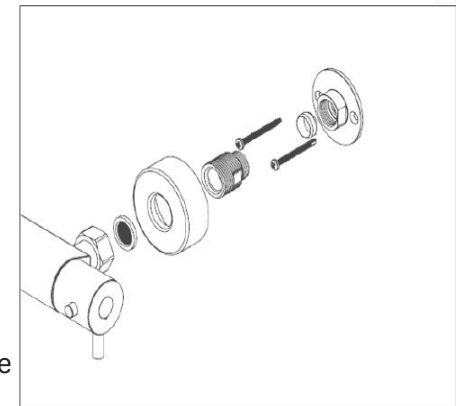
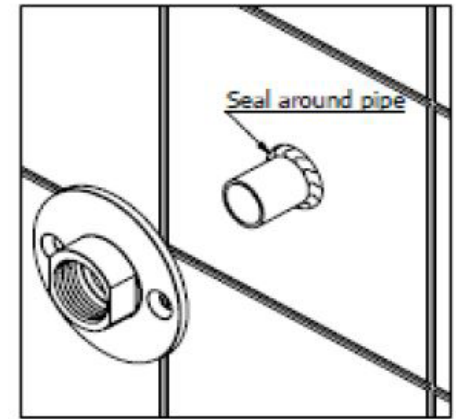

Installation Instructions Continued

- 10) Place the mounting bracket over the pipework.
- 11) Place the olive over onto the exposed pipe.
- 12) Take one of the threaded connectors, slide the connector over the pipework and loosely fit the threaded connector into the mounting bracket.
- 13) Screw the mounting bracket to the wall.
- 14) Using two spanners, one to be located on the mounting bracket and the other to be located on the threaded adaptor then tighten the thread adaptor to the mounting bracket. Note: Ensure that two spanners are used to ensure that you do not tighten the assemble against the mounting bracket screws. Failure to do so may result in the mounting becoming loose.
- 15) Repeat steps 4 – 14 for the second fitting, ensuring that the bar is level on the wall.
- 16) To fit the trim plates, screw on the threaded insert until it reaches the finished wall lining and align accordingly. At this stage the pipe should be flushed of any debris. Failure to do so may result in the filter of the bar valve becoming prematurely blocked and reduce its performance.
- 17) Ensuring seals and filters are correctly located in the inlet unions of the bar valve, screw the unions of the bar valve to the easy fix connections and tighten.
- 18) Turn on the hot and cold water supplies and check for leaks.

Temperature Adjustment/Commissioning

- 1) Turn the temperature control to the mixed position (marked 38°C on the handle).
- 2) Turn on the water to the bath filler and using a thermometer take a temperature reading.
- 3) If the temperature requires adjustment prise the cap out of the centre of the temperature control handle.
- 4) Remove the handle screw and pull the handle off the top of the thermostatic cartridge.
- 5) With the handle removed rotate the spindle, anti-clockwise to increase clockwise to decrease.

- 6) Once the desired temperature is achieved re-fit the handle in the mixed position, so that the handle cannot be rotated any further clockwise without depressing the override button.

Commissioning and Testing

The thermostatic mixing valve is factory set to the indicated temperature. Check the product after installation to ensure that it operates at the correct outlet temperature.

A temperature difference of at least 10°C should be maintained between the mixed and system hot water.

After commissioning carry out a cold water failure test to ensure the valve is operating correctly.

If some adjustment is required to the temperature, this should only be carried out when necessary, by a competent person.

The valve should be tested to ensure correct operation at commissioning and thereafter at stated intervals decided by the user but never greater than a 12 Monthly period.

The testing will only require a normal thermometer with a scale greater than 65°C. The temperature sensitive element of the thermometer should always be fully inserted into the water flow.

Measure the mixed water temperature.

Carry out a cold fail/safe shut off test by using the isolation valve to shut off the water to the cold supply.

Wait 5 seconds, if the water is still flowing check that the water temperature is below 46°C. the flow of water should reduce to a trickle or stop completely.

Open the cold water isolation valve and measure mixed water temperature.

If there is no significant change from the original settings and the fail/safe shut off is functioning the valve is working correctly and no further service is required.

If the outlet temperature has drifted by more than 2°C, or if the fail/safe function does not work, a full service or re-commissioning is required.

The manufacturer of the valve recommends that in these circumstances you contact a competent person for servicing or ring 0800 195 1602 for further advice.