

Warranty Information

Proof of purchase will be required.

The guarantee does not cover faults or damage caused by incorrect installation and/or maintenance, ordinary wear and tear, water composition, etc.

*Please see www.deva-uk for full terms and conditions of warranty

Cleaning

Your product has a high-quality finish and should be treated with care to preserve the visible surfaces. Never use abrasives or abrasive cleaning agents to clean this product clean regularly with contamination free warm water and a damp soft cloth. Do not use products containing chlorine bleach or hydrochloric acid as these can damage the product.

We have a policy of continuous improvement and reserve the right to change specifications without notice.

METHVEN UK LIMITED
METHVEN EXPERIENCE CENTRE
3/3A STONE CROSS COURT
YEW TREE WAY
GOLBORNE
WARRINGTON
WA3 3JD
UNITED KINGDOM

TEL: 0800 195 1602
FAX: 0844 406 8690
EMAIL: sales@uk.methven.com
www.deva-uk.com
www.methven.com

INST-MTBSMBB, MTBSMBK,
MTBSMBN, MTBSMCP &
MTBSMGM -V1 21.06.2021

Motu Bath Shower Mixer

MTBSMBB, MTBSMBK, MTBSMBN, MTBSMCP
& MTBSMGM

Installation Guide

Technical Specification

Working Pressure:

Min: 0.3 Bar

Max: 5.0 Bar

Operating Temperature:

Hot: 65°C

Cold: 5°C





Inlet Connections:

3/4" BSP

Features:

- On Trend Finishes For A Designer Look
- Contemporary Single Lever Design
- Complete With Satinjet Handset Regulated To 8 l/minute & Wall Bracket
- Water Efficient Without Compromising Showering Performance
- Ceramic disc handles ensure a smooth operation
- Products which are easy to use by all the family
- 20 Year Warranty on Chrome Finish
- 5 Year Warranty on PVD Finish



-  Chrome
-  Matte Black
-  PVD Brushed Brass
-  PVD Gunmetal
-  PVD Brushed Nickel



METHVEN
www.methven.com EST 1886

Contents

Congratulations on your purchase of your new Methven Bath Shower Mixer. Our fitting instructions have been created with you in mind to provide you with all the information you require and, if you need any further help, please don't hesitate to contact our customer care team on 0800 195 1602.

General Safety Information 3

Line Drawing 3

Product Breakdown 4

Product Breakdown 4

Installation Requirements 6

Installation 6

Troubleshooting 7

Warranty Information 8

Cleaning 8

Troubleshooting

Symptom	Cause(s)	Resolution
No flow or low flow rate	Partially closed isolation valve	Open isolation valve
	Instantaneous water heater cycles on and off as flow rate or pressure is too low	Increase water flow rate or pressure through system.
	Air lock or partial blockage in the supply pipework or hoses	Flush through pipework to ensure removal of debris and any airlocks.
	Hot or cold water being drawn off elsewhere causing pressure changes or instantaneous boiler temperature changes.	Try not to use other water outlets when using the mixer
Water dripping from the mixer	This is normal for a short time after using the mixer	This is due to residual water tension, the build up of water in the tap body.
	If water continues to drip, possible issue with the flow control cartridge.	Please contact our customer care team.
Mixer does not turn on	Closed isolation valve	Open isolation valve
	Mains water supply turned off	Turn on mains water supply

Installation Requirements

Before commencing installation of the new product, ensure that the system has been flushed to remove any debris, which could cause damage to the valves and invalidate the warranty.

Installation

1. Remove the Backnut (8) and Backnut Washer (7) from Thread Pipe (6)
2. Then place the Thread Pipes through the bath holes with the Base Plate (5) and Base Plate Washer (9) correctly positioned under each pillar, fully covering the mounting holes.
3. Place the Backnut Washer (7) and Backnuts (8) back onto the Thread Pipes, under the bath and screw up until the tap is secured in position (DO NOT OVERTIGHTEN)

NOTE: Additional sealant can be used if required.

4. Connect the water supply pipes to the tails and tighten
5. An adequate sealing method should be used to create a watertight seal.
6. Identify a suitable location for the wall bracket, so that the hose will not be under tension when fitted.
7. Attach to the wall using the plugs and screws supplied
8. Fit a hose washer into each side of the hose
9. Connect one end of the hose to mixer outlet and the other end to the handset.
10. Reinstate the water supply and check for any leaks.

Please keep these instructions for future reference and request of replacement parts

General Safety Information

Please read all of the instructions before installation.

Methven recommends this product is installed by a competent person in compliance with all relevant regional regulations.

Remove all packaging and check the components for damage before starting installation.

This product **must** not be modified in any way as this will invalidate the guarantee.

It is the responsibility of the installer to ensure a waterproof seal is achieved, after installation all connections must be checked for leaks.

All outlets used primarily for personal hygiene shall deliver water at a safe temperature as per regional regulations.

Line Drawing

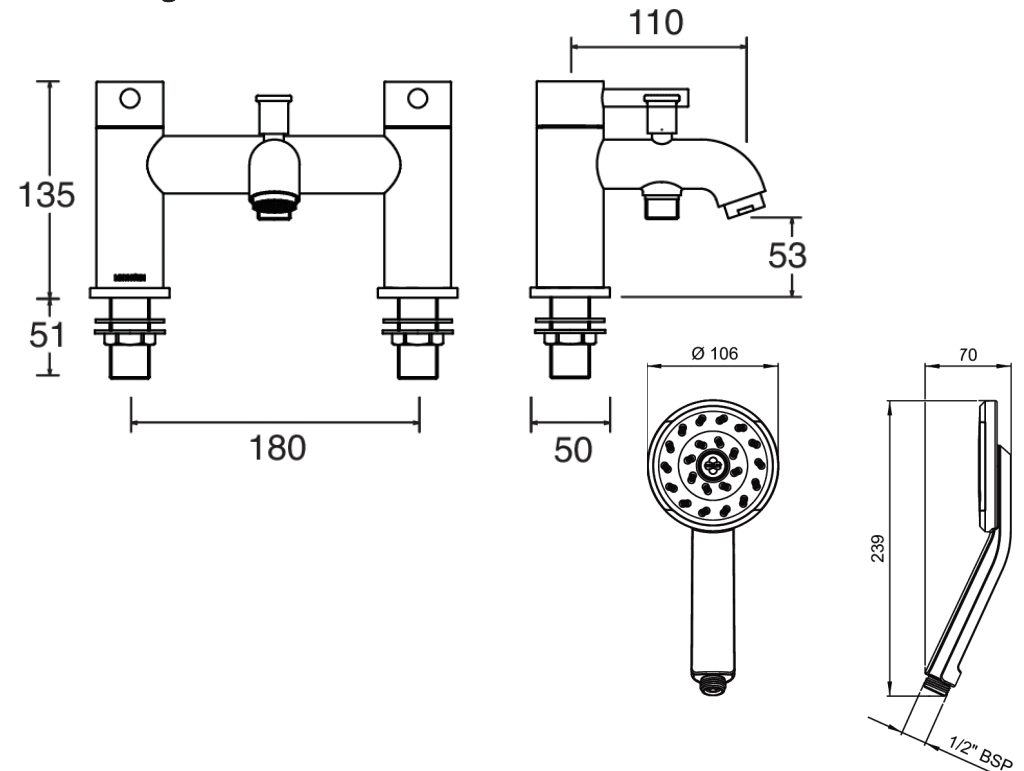

Product Breakdown

Check All components are present prior to starting installation.

Part Number	Description
1	Handle Lever
2	Screw
3	Handle Body
4	Screw
5	Cartridge Shroud
6	Cartridge
7	Body
8	Base Plate
9	Washer
10	O-Ring
11	Tail Pipes
12	Washer
13	Back nut
14	Diverter
15	Connector
16	O-Ring
17	Spring
18	O-Ring
19	Diverter Stem
20	Washer
21	O-Ring
22	Hose Connector
23	Cartridge
24	O-Ring
25	Aerator
26	Nozzle
27	1.5m Hose
28	Satinjet Handset

