

# 1 1/4" Bottle Trap with 300mm Wall Extension

VSN625, VSN625BK, VSN625BB,  
VSN625BN, VSN625GM

Installation Instructions & Maintenance Guide

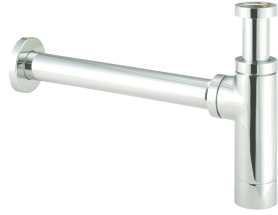

This product should be fitted in compliance with Water Regulations, by a qualified plumber.

## Care & Cleaning

Your product has a high-quality finish and should be treated with care to preserve the visible surfaces. Never use abrasives or abrasive cleaning agents to clean this product. Clean regularly with contamination free warm water and a damp soft cloth. Do not use products containing chlorine bleach or hydrochloric acid as these can damage the product.

## Warranty Information

**Your product has a warranty of 1 year.**

Proof of purchase will be required.

The guarantee does not cover faults or damage caused by incorrect installation and/or maintenance, ordinary wear and tear, water composition, etc.

\*Please see [www.deva-uk.com](http://www.deva-uk.com) for full terms and conditions of warranty

**We have a policy of continuous improvement and reserve the right to change specifications without notice.**

METHVEN UK LIMITED  
METHVEN EXPERIENCE CENTRE  
3/3A STONE CROSS COURT  
YEW TREE WAY  
GOLBORNE  
WARRINGTON  
WA3 3JD  
UNITED KINGDOM

TEL: 0800 195 1602  
FAX: +44 (0) 1942 680 190  
EMAIL: [sales@uk.methven.com](mailto:sales@uk.methven.com)  
[www.deva-uk.com](http://www.deva-uk.com)  
[www.methven.com](http://www.methven.com)



# 1 1/4" Bottle Trap with 300mm Wall Extension

VSN625, VSN625BK, VSN625BB,  
VSN625BN, VSN625GM

Installation Instructions & Maintenance Guide

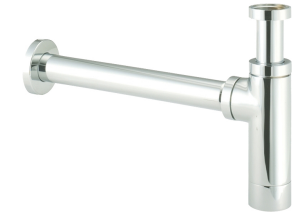

This product should be fitted in compliance with Water Regulations, by a qualified plumber.

## Care & Cleaning

Your product has a high-quality finish and should be treated with care to preserve the visible surfaces. Never use abrasives or abrasive cleaning agents to clean this product. Clean regularly with contamination free warm water and a damp soft cloth. Do not use products containing chlorine bleach or hydrochloric acid as these can damage the product.

## Warranty Information

**Your product has a warranty of 1 year.**

Proof of purchase will be required.

The guarantee does not cover faults or damage caused by incorrect installation and/or maintenance, ordinary wear and tear, water composition, etc.

\*Please see [www.deva-uk.com](http://www.deva-uk.com) for full terms and conditions of warranty

**We have a policy of continuous improvement and reserve the right to change specifications without notice.**

METHVEN UK LIMITED  
METHVEN EXPERIENCE CENTRE  
3/3A STONE CROSS COURT  
YEW TREE WAY  
GOLBORNE  
WARRINGTON  
WA3 3JD  
UNITED KINGDOM

TEL: 0800 195 1602  
FAX: +44 (0) 1942 680 190  
EMAIL: [sales@uk.methven.com](mailto:sales@uk.methven.com)  
[www.deva-uk.com](http://www.deva-uk.com)  
[www.methven.com](http://www.methven.com)



## INSTALLATION

The main body of the bottle trap is supplied fully assembled. Check all components shown on the diagram are present.

- Before commencing installation, loosen the connection nut (3) to enable free movement of the adjustable metal tube.
- Ensure the flat sealing washer (1) is fitted into the top of the connecting nut. The trap has a standard 1 1/4" (32mm) connection. Fit the trap to the waste outlet.
- Fit the conical washer (6) and the connecting nut (7) to the extension tube (10). Assemble this to the main trap body(5) , ensuring the extension tube is fully inserted into the outlet and tighten the connecting nut.
- Slide the wall plate (12) onto the extension tube and position as required. The extension pipe is designed to fit onto a standard 1 1/4" waste pipe.
- Set the required height of the adjustable tube (2) by tightening the connecting nut (3). Check for leaks.

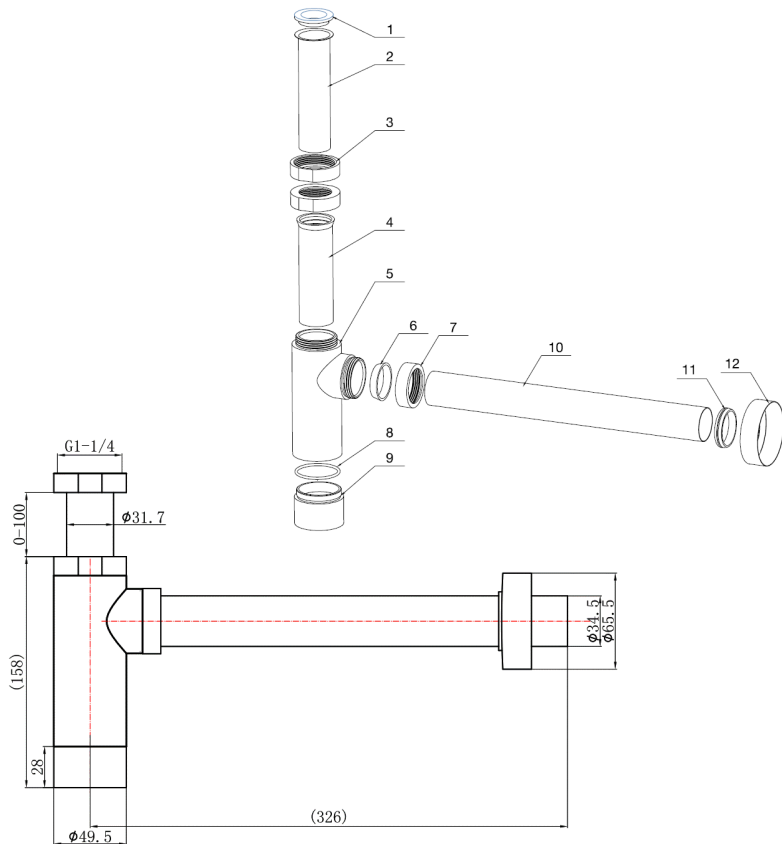

## INSTALLATION

The main body of the bottle trap is supplied fully assembled. Check all components shown on the diagram are present.

- Before commencing installation, loosen the connection nut (3) to enable free movement of the adjustable metal tube.
- Ensure the flat sealing washer (1) is fitted into the top of the connecting nut. The trap has a standard 1 1/4" (32mm) connection. Fit the trap to the waste outlet.
- Fit the conical washer (6) and the connecting nut (7) to the extension tube (10). Assemble this to the main trap body(5) , ensuring the extension tube is fully inserted into the outlet and tighten the connecting nut.
- Slide the wall plate (12) onto the extension tube and position as required. The extension pipe is designed to fit onto a standard 1 1/4" waste pipe.
- Set the required height of the adjustable tube (2) by tightening the connecting nut (3). Check for leaks.

