

Warranty Information

Proof of purchase will be required.

The guarantee does not cover faults or damage caused by incorrect installation and/or maintenance, ordinary wear and tear, water composition, etc.

*Please see www.deva-uk for full terms and conditions of warranty

Cleaning

Your product has a high-quality finish and should be treated with care to preserve the visible surfaces. Never use abrasives or abrasive cleaning agents to clean this product clean regularly with contamination free warm water and a damp soft cloth. Do not use products containing chlorine bleach or hydrochloric acid as these can damage the product.

We have a policy of continuous improvement and reserve the right to change specifications without notice.

METHVEN UK LIMITED
METHVEN EXPERIENCE CENTRE
3/3A STONE CROSS COURT
YEW TREE WAY
GOLBORNE
WARRINGTON
WA3 3JD
UNITED KINGDOM

TEL: 0800 195 1602
FAX: 0844 406 8690
EMAIL: sales@uk.methven.com
www.deva-uk.com
www.methven.com

INST-WAIFMBSMBK, WAIFMBSMBB,
WAIFMBSMBN & WAIFMBSMGM
V2 30.11.2023

Wai Floor Mounted Bath Shower Mixer

WAIFMBSMBK, WAIFMBSMBB, WAIFMBSMBN & WAIFMBSMGM

Installation Guide

Technical Specification

Working Pressure:

Min: 0.3 Bar

Max: 5.0 Bar

Operating Temperature:

Hot: 65°C

Cold: 5°C

Inlet Connections:

½" BSP

Features:

- On trend finish for a designer look
- Contemporary square design
- Ceramic Cartridge for smooth operation
- Complete with Waipori Satinjet handset regulated to 8 l/minute
- Water efficient without compromising showering performance
- Lifetime Warranty on Satinjet Handset
- 5 Year Warranty on outer coloured finish



METHVEN
www.methven.com EST 1886

Contents

Congratulations on your purchase of your new Methven Wai Floor Mounted Bath Shower Mixer. Our fitting instructions have been created with you in mind to provide you with all the information you require and, if you need any further help, please don't hesitate to contact our customer care team on 0800 195 1602.

General Safety Information 3

Line Drawing 3

Product Breakdown 4

Product Breakdown 4

Installation Requirements 6

Installation 6

Troubleshooting 7

Warranty Information 8

Cleaning 8

Troubleshooting

Symptom	Cause(s)	Resolution
No flow or low flow rate	Partially closed isolation valve	Open isolation valve
	Instantaneous water heater cycles on and off as flow rate or pressure is too low	Increase water flow rate or pressure through system.
	Air lock or partial blockage in the supply pipework or hoses	Flush through pipework to ensure removal of debris and any airlocks.
	Hot or cold water being drawn off elsewhere causing pressure changes or instantaneous boiler temperature changes.	Try not to use other water outlets when using the mixer
Water dripping from the mixer	This is normal for a short time after using the mixer	This is due to residual water tension, the build up of water in the tap body.
	If water continues to drip, possible issue with the flow control cartridge.	Please contact our customer care team.
Mixer does not turn on	Closed isolation valve	Open isolation valve
	Mains water supply turned off	Turn on mains water supply

Installation Requirements

Before commencing installation of the new product, ensure that the system has been flushed to remove any debris, which could cause damage to the valves and invalidate the warranty.

Installation

1. Place fixing plate on the floor in required position and mark hole locations
2. Drill Holes into the floor in the marked positions
3. Place wall plugs into the holes
4. Connect the flexi hoses to the hot and cold water supply and match the holes.
5. Turn on water supply and check for leaks
6. Line the fixing plate to the wall plugs with the tap in the correct position
7. Tighten the screws until standpipe is held secure
8. Tighten the nut to secure onto the fixing plate
9. Slide cover plate down over the fixing plate
10. Test the tap for leaks

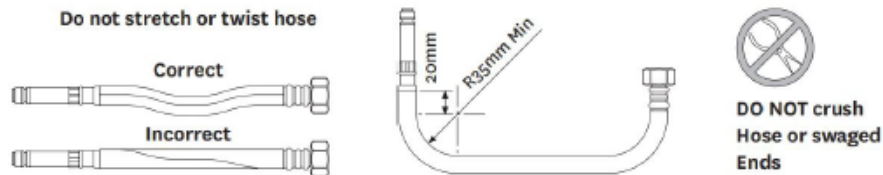

Please keep these instructions for future reference and request of replacement parts

General Safety Information

Please read all of the instructions before installation.

Methven recommends this product is installed by a competent person in compliance with all relevant regional regulations.

Remove all packaging and check the components for damage before starting installation.

This product **must** not be modified in any way as this will invalidate the guarantee. It is the responsibility of the installer to ensure a waterproof seal is achieved, after installation all connections must be checked for leaks.

All outlets used primarily for personal hygiene shall deliver water at a safe temperature as per regional regulations.

Line Drawing

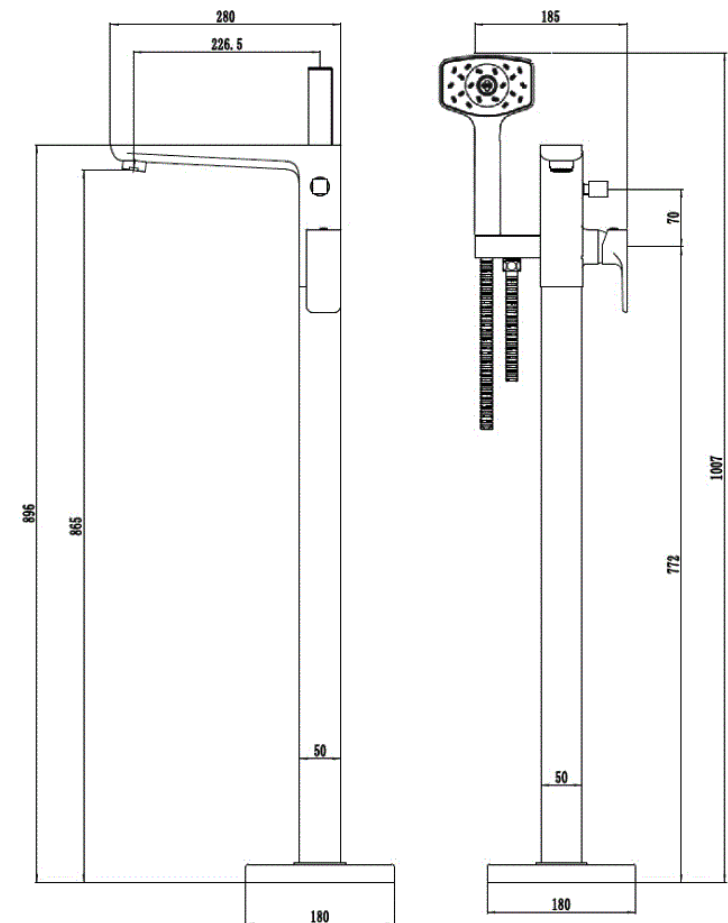

Product Breakdown

Check All components are present prior to starting installation.

Item	Description
1	Spout
2	Stem
3	O-Ring
4	O-Ring
5	O-Ring
6	Spring
7	Divertor
8	Divertor Cap
9	Badge
10	Screw
11	Handle
12	Cartridge Cover
13	Cartridge Cap
14	Cartridge
15	Screws & Wall Plugs
16	Nut
17	Flexi Tails
18	Flange
19	Thread Bar
20	Cover Plate
21	Square Rubber Washer
22	Square Pipe
23	Nozzle
24	Aerator
25	Washer
26	O-Ring
27	Connector
28	O-Ring
29	Connector
30	O-Ring
31	Shower Handset Holder
32	Screw
33	Hose Connector
34	O-Ring
35	Shower hose
36	Shower Handset

